

Customer \_\_\_\_\_ Date \_\_\_\_\_

Contact information \_\_\_\_\_

### INSTRUCTIONS FOR ORDERING MULTI-BEAM COLUMN CAPS:

- 1. CHOOSE COLUMN CAP STYLE:** Choose the style of cap you require by checking one of the boxes below. Refer to your plans if you are not sure on the style you require.
- 2. DETERMINE THE DIMENSIONS OF THE CAP:** Fill out the dimensions of the members in the connection, in the Post and Beam Dimensions section, and then follow the footnotes, in the Column Cap Dimensions section, to fill in the dimensions of the Column Cap.
- 3. DETERMINE THE VERTICAL ALIGNMENT OF THE BEAM:** Check the box in the Vertical Alignment section that best represents your connection.

- 4. STRAP ORIENTATION:** Check the box that represents the strap orientation you require.
- 5. SELECT FINISH OF CAP:** The standard Column Cap comes in USP grey primer. For Hot-dip galvanized specify "HDG".
- 6. PLACE ORDER:** Contact USP Structural Connector for ordering information.

Beam material / wood species _____		
Factored load (lb):		
Beam A _____	Beam B _____	Beam C _____

### 1. COLUMN CAP STYLE

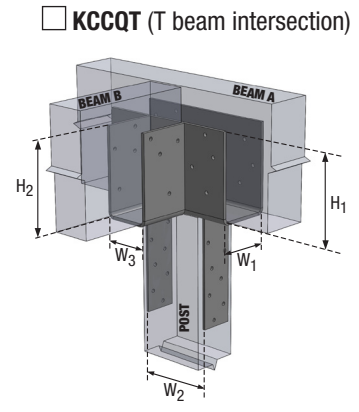
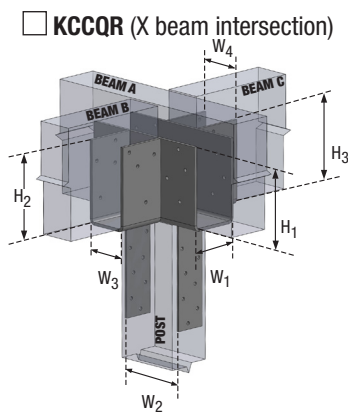
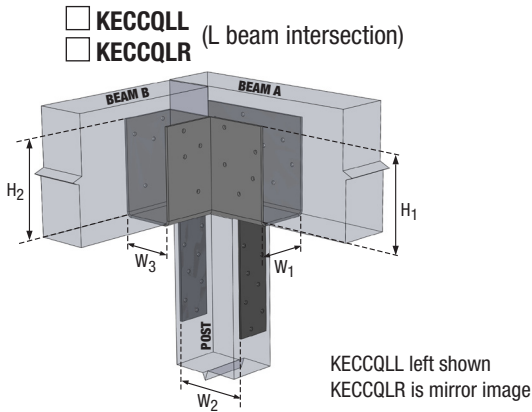

### 2. POST AND BEAM DIMENSIONS:

Provide dimensions in **actual inches** (not nominal dimensions).

Beam	A	B	C
Width	_____	_____	_____
Height	_____	_____	_____
Post Size:	_____		

### COLUMN CAP DIMENSIONS:

$W_1 =$ _____	$H_1 =$ _____
$W_3 =$ _____	$H_2 =$ _____
$W_4 =$ _____	$H_3 =$ _____
$W_2 =$ _____	

$W_1, W_3, W_4$  will typically be 1/8"–1/4" greater than beam widths.  
 $W_2$  will typically be 0"–1/8" greater than post width.

### 3. VERTICAL ALIGNMENT

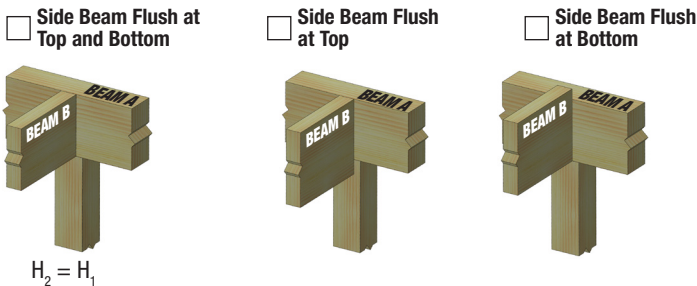

- 5. CAP FINISH:**  Standard USP Primer  HDG

### 4. STRAP ORIENTATION

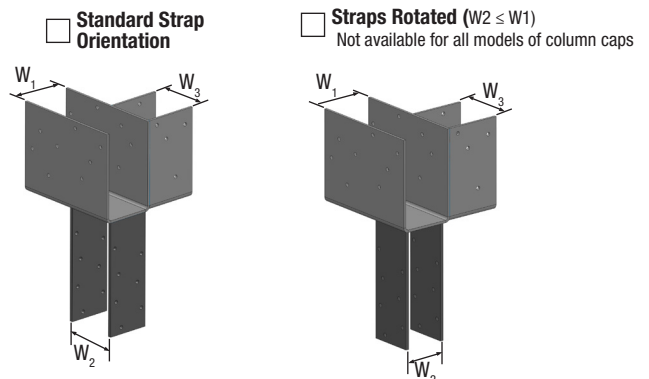

Additional information \_\_\_\_\_

Stock No.	W1	W2	W3	H1	H2	Side Stirrup Direction
KECCLQ325-4	3-1/4	3-5/8	3-1/4	6-1/2	6-1/2	Specify Left or Right
KECCLQ325-6	3-1/4	5-1/2	3-1/4	6-1/2	6-1/2	
KECCLQ44	3-5/8	3-5/8	3-5/8	6-1/2	6-1/2	Specify Left
KECCLL44	3-5/8	3-5/8	3-5/8	6-1/2	6-1/2	
KECCLR44	3-5/8	3-5/8	3-5/8	6-1/2	6-1/2	Specify Right
KECCLQ45	3-5/8	5-3/8	3-5/8	6-1/2	6-1/2	
KECCLQ46	3-5/8	5-1/2	3-5/8	6-1/2	6-1/2	Specify Left or Right
KECCLL46	3-5/8	5-1/2	3-5/8	6-1/2	6-1/2	
KECCLR46	3-5/8	5-1/2	3-5/8	6-1/2	6-1/2	Specify Left
KECCLQ47	3-5/8	7-1/8	3-5/8	6-1/2	6-1/2	
KECCLQ47X	3-5/8	7-1/8	3-5/8	6-1/2	6-1/2	Specify Right
KECCLQ48	3-5/8	7-1/2	3-5/8	6-1/2	6-1/2	
KECCLQ525-4	5-1/4	3-5/8	5-1/4	8	8	Specify Left or Right
KECCLQ525-6	5-1/4	5-1/2	5-1/4	8	8	
KECCLQ525-8	5-1/4	7-1/2	5-1/4	8	8	
KECCLQ57	5-3/8	7-1/8	5-3/8	6-1/2	6-1/2	
KECCLQ64	5-1/2	3-5/8	5-1/2	6-1/2	6-1/2	Specify Left
KECCLQ66	5-1/2	5-1/2	5-1/2	6-1/2	6-1/2	
KECCLL66	5-1/2	5-1/2	5-1/2	6-1/2	6-1/2	Specify Right
KECCLR66	5-1/2	5-1/2	5-1/2	6-1/2	6-1/2	
KECCLQ67X	5-1/2	7-1/8	5-1/2	6-1/2	6-1/2	Specify Left or Right
KECCLQ68	5-1/2	7-1/2	5-1/2	6-1/2	6-1/2	
KECCLQ74	6-7/8	3-5/8	6-7/8	6-1/2	6-1/2	Specify Left or Right
KECCLQ76	6-7/8	5-1/2	6-7/8	6-1/2	6-1/2	
KECCLQ77	6-7/8	6-7/8	6-7/8	6-1/2	6-1/2	Specify Left or Right
KECCLQ78	6-7/8	7-1/2	6-7/8	6-1/2	6-1/2	
KECCLQ71-4	7-1/8	3-5/8	7-1/8	6-1/2	6-1/2	Specify Left or Right
KECCLQ71-6	7-1/8	5-1/2	7-1/8	6-1/2	6-1/2	
KECCLQ71-71	7-1/8	7-1/8	7-1/8	6-1/2	6-1/2	Specify Left or Right
KECCLQ71-8	7-1/8	7-1/2	7-1/8	6-1/2	6-1/2	
KECCLQ84	7-1/2	3-5/8	7-1/2	6-1/2	6-1/2	Specify Left or Right
KECCLQ86	7-1/2	5-1/2	7-1/2	6-1/2	6-1/2	
KECCLQ88	7-1/2	7-1/2	7-1/2	6-1/2	6-1/2	Specify Left or Right
KECCLQ94	8-7/8	3-5/8	8-7/8	6-1/2	6-1/2	
KECCLQ96	8-7/8	5-1/2	8-7/8	6-1/2	6-1/2	Specify Left or Right
KECCLQ98	8-7/8	7-1/2	8-7/8	6-1/2	6-1/2	
KECCLQ106	9-1/2	5-1/2	9-1/2	6-1/2	6-1/2	

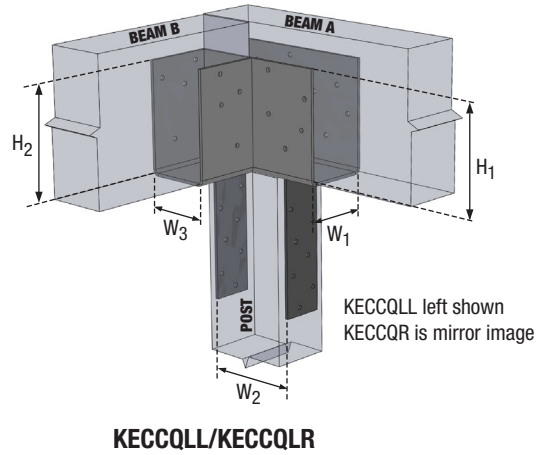

Stock No.	W1	W2	W3	W4	H1	H2	H3
KCCQC325-4	3-1/4	3-5/8			6-1/2		
KCCQC325-6	3-1/4	5-1/2			6-1/2		
KCCQC44	3-5/8	3-5/8			6-1/2		
KCCQC45	3-5/8	5-3/8			6-1/2		
KCCQC46	3-5/8	5-1/2			6-1/2		
KCCQC47	3-5/8	7-1/8			6-1/2		
KCCQC47X	3-5/8	7-1/8			6-1/2		
KCCQC48	3-5/8	7-1/2			6-1/2		
KCCQC525-4	5-1/4	3-5/8			8		
KCCQC525-6	5-1/4	5-1/2			8		
KCCQC525-8	5-1/4	7-1/2			8		
KCCQC57	5-3/8	7-1/8			6-1/2		
KCCQC64	5-1/2	3-5/8			6-1/2		
KCCQC66	5-1/2	5-1/2			6-1/2		
KCCQC67X	5-1/2	7-1/8			6-1/2		
KCCQC68	5-1/2	7-1/2	Specify	Specify	6-1/2	Specify	Specify
KCCQC74	6-7/8	3-5/8			6-1/2		
KCCQC76	6-7/8	5-1/2			6-1/2		
KCCQC77	6-7/8	6-7/8			6-1/2		
KCCQC78	6-7/8	7-1/2			6-1/2		
KCCQC71-4	7-1/8	3-5/8			6-1/2		
KCCQC71-6	7-1/8	5-1/2			6-1/2		
KCCQC71-71	7-1/8	7-1/8			6-1/2		
KCCQC71-8	7-1/8	7-1/2			6-1/2		
KCCQC84	7-1/2	3-5/8			6-1/2		
KCCQC86	7-1/2	5-1/2			6-1/2		
KCCQC88	7-1/2	7-1/2			6-1/2		
KCCQC94	8-7/8	3-5/8			6-1/2		
KCCQC96	8-7/8	5-1/2			6-1/2		
KCCQC98	8-7/8	7-1/2			6-1/2		
KCCQC106	9-1/2	5-1/2			6-1/2		

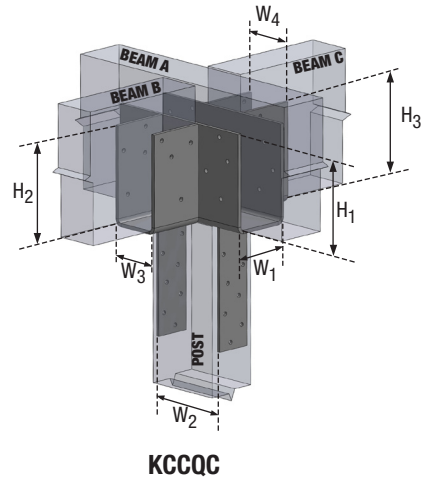

Stock No.	W1	W2	W3	H1	H2
KCCQT0325-4	3-1/4	3-5/8		6-1/2	
KCCQT0325-6	3-1/4	5-1/2		6-1/2	
KCCQT044	3-5/8	3-5/8		6-1/2	
KCCQT045	3-5/8	5-3/8		6-1/2	
KCCQT046	3-5/8	5-1/2		6-1/2	
KCCQT047	3-5/8	7-1/8		6-1/2	
KCCQT047X	3-5/8	7-1/8		6-1/2	
KCCQT048	3-5/8	7-1/2		6-1/2	
KCCQT0525-4	5-1/4	3-5/8		8	
KCCQT0525-6	5-1/4	5-1/2		8	
KCCQT0525-8	5-1/4	7-1/2		8	
KCCQT057	5-3/8	7-1/8		6-1/2	
KCCQT064	5-1/2	3-5/8		6-1/2	
KCCQT066	5-1/2	5-1/2		6-1/2	
KCCQT067X	5-1/2	7-1/8		6-1/2	
KCCQT068	5-1/2	7-1/2		6-1/2	
KCCQT074	6-7/8	3-5/8	Specify	6-1/2	Specify
KCCQT076	6-7/8	5-1/2		6-1/2	
KCCQT077	6-7/8	6-7/8		6-1/2	
KCCQT078	6-7/8	7-1/2		6-1/2	
KCCQT071-4	7-1/8	3-5/8		6-1/2	
KCCQT071-6	7-1/8	5-1/2		6-1/2	
KCCQT071-71	7-1/8	7-1/8		6-1/2	
KCCQT071-8	7-1/8	7-1/2		6-1/2	
KCCQT084	7-1/2	3-5/8		6-1/2	
KCCQT086	7-1/2	5-1/2		6-1/2	
KCCQT088	7-1/2	7-1/2		6-1/2	
KCCQT094	8-7/8	3-5/8		6-1/2	
KCCQT096	8-7/8	5-1/2		6-1/2	
KCCQT098	8-7/8	7-1/2		6-1/2	
KCCQT106	9-1/2	5-1/2		6-1/2	

